

## DG Flugzeugbau GmbH

Otto-Lilienthal-Weg 2 / Am Flugplatz • D-76646 Bruchsal • Germany  
Postbox 1480, D-76604 Bruchsal • Germany  
Tel. 07251 3020-100 • Telefax 07251 3020-200 • eMail: dg@dg-flugzeugbau.de  
Spare part and material sales: Tel. 07251 3020-270 • lager@dg-flugzeugbau.de  
www.dg-flugzeugbau.de

### FLIGHT MANUAL

for the

### SAILPLANE

# DG-500 ELAN Orion

Model: DG-500 ELAN Orion

German Data Sheet No.: 348

Factory Serial No.: \_\_\_\_\_

Registration No.: \_\_\_\_\_

Date of Issue: November 1995

Pages as indicated by "App." are approved by:

(Signature)



(Authority)

Anerkannt durch  
Luftfahrt-Bundesamt

(Stamp)



(Original date of approval)

10. Nov. 95

This sailplane is to be operated in compliance with information and limitations contained herein.

The original German Language edition of this manual has been approved as operating instruction according to "Paragraph 12(1) 2. of Luft-Ger Po".  
Approval of translation has been done by best knowledge and judgement.

DG Flugzeugbau GmbH

Enclosure to flight manual

### Warnings

All sailplanes, especially those with retractable powerplants, are very complex technical devices. If you don't use yours as it is intended and within the certified operating limitations or if you fail to carry out proper maintenance work, it may harm your health or place your life in danger.

Prior to flying the aircraft read all manuals carefully and regard especially all warnings, caution remarks and notes given in the manuals.

- Never take off without executing a serious pre-flight inspection according to the flight manual!
- Never take-off with a motorglider without checking the max. engine RPM and the ignition circuits!
- Always respect the relevant safety altitudes!
- With a motorglider never rely completely on the engine extending and starting. Plan your flight path so that you are always able to carry out a safe outlanding if necessary. Be aware that with the engine extended but not running the rate of sink increases remarkably. This means that with a motorglider you have to decide earlier for an outlanding than with a pure sailplane.
- Selflaunch only if you are sure that with an engine failure during the initial climb there is the possibility to execute a safe outlanding or to return to the airfield.
- Respect the stall speeds and always fly with a safety margin above the stall speed according to the flight conditions, especially at low altitudes and in the mountains.
- Use only the types of fuel and oil for your motorglider as specified in the flight manual.
- Use only the battery chargers as specified in the flight manual.
- Don't execute yourself any work on the control system except for greasing.
- Repairs and maintenance work should only be accomplished by the manufacturer or at certified repair stations rated for this type of work. A list of stations which have experience with DG aircraft may be obtained from DG Flugzeugbau..
- Even if no annual inspections are required in your country, have your aircraft checked annually, see maintenance manual section 2.

Issued February 1999 DG Flugzeugbau GmbH

## Flight manual DG-500 ELAN ORION

### 0.1 Record of revisions

Any revision of the present manual, except actual weighing data, must be recorded in the following table and in case of approved sections endorsed by the responsible airworthiness authority.

The new or amended text in the revised page will be indicated by a black vertical line in the right hand margin, and the Revision No. and the date will be shown on the bottom left hand of the page.

Rev. No.	Affected pages / section	Description	Issue Date	LBA Approval Date	Inserted Date Signature
1	0.3, 0.4, 1.4, 2.8, 4.11, 6.4, 6.8	TN 348/8 Ser.no 5E155-159 +5E164 only	Jan. 96	02.04.96	
2	0.3, 4.11	ÄM 500/9/96 not for Ser.no 5E155-159 +5E164	Mar. 96	12.06.96	
3	0.3, 0.4, 4.2, 4.18, 5.6, 6.7, 7.1, 7.9, 7.10	TN 348/9	Oct. 97	26.11.97	
4	0.1, 0.3, 0.4, 2.3, 2.4, 2.5, 2.6, 2.7, 2.8, 4.7, 4.16, 4.18, 6.6, 7.6	Manual revision TN 348/14	March 2000	09.05.00	
5	0.3,0.4, 4.7, 7.6, 8.2	TN 348/15	Jan. 2001	07.02.01	
6	0.4, 7.5, 7.5a	TN 348/16 Parking brake/ Piggott-hook	February 2004	25.02.04	
Rev. No.	Affected pages / section	Description	Issue Date	EASA Approval Date	Inserted Date Signature
7	0.3, 0.4, 2.6, 2.7, 3.2-3.4, 4.1, 4.7, 4.15, 7.1, 7.8	TN 348/20 manual revision	May 2008	August 1. 2008	
8	0.4, 9.1, 9.2	Special equipment for very small pilots TN500/02	May 2010	20.07. 2010	

## Flight manual DG-500 ELAN ORION

Rev. No.	Affected pages / section	Description	Issue Date	EASA Approval Date	Inserted Date Signature
9	0.2, 0.3, 0.4, 4.7, 4.8, 7.1, 7.10	TN500/13 Canopy lock, rear locking rods	July 2019	17.09. 2019	

# Flight manual DG-500 ELAN ORION

## 0.2 List of effective pages

Section	page	issued	replaced	replaced	replaced	replaced
0	0.0	July 95				
	0.1	/				
	0.2	/				
	0.3	see record of revisions				
	0.4	"				
	0.5	July 95				
1	1.1	"				
	1.2	Nov. 95				
	1.3	July 95				
	1.4	"				
	1.4	Jan. 96 (only ser.no. 5E155-159)				
	1.5	July 95				
2	App. 2.1	"				
	" 2.2	"				
	" 2.3	"	March 00			
	" 2.4	"	March 00			
	" 2.5	"	March 00			
	" 2.6	"	March 00	May 08		
	" 2.7	"	March 00	May 08		
	" 2.8	"	Jan. 96	March 00		
	" 2.9	"				
	3	" 3.1	"			
" 3.2		"	May 08			
" 3.3		"	May 08			
" 3.4		"	May 08			
4	" 4.1	"	May 08			
	" 4.2	"	Oct. 97			
	" 4.3	"				
	" 4.4	"				
	" 4.5	"				
	" 4.6	"				
	" 4.7	"	March 00	Jan. 01	May 08	July 19
	" 4.8	"	July 19			
	" 4.9	"				
	" 4.10	"				
	" 4.11	"				
	" 4.11	Jan. 96 (only ser.no. 5E155-159)				
	" 4.12	July 95				
	" 4.13	"				
	" 4.14	"				
	" 4.15	"	May 08			
	" 4.16	"	March 00			
	" 4.17	"				
	" 4.18	"	Oct. 97	March 00		
	" 4.19	"				
App. 4.20	July 95					

## Flight manual DG-500 ELAN ORION

### 0.2 List of effective pages (cont.)

<u>Section</u>	<u>page</u>	<u>issued</u>	<u>replaced</u>	<u>replaced</u>	<u>replaced</u>
5	App. 5.1	July 95			
	" 5.2	"			
	" 5.3	"			
	App. 5.4	"			
	5.5	"			
	5.6	"	Oct. 97		
6	6.1	"			
	6.2	"			
	6.3	"			
	6.4	"			
	6.4	Jan. 96 (only ser.no. 5E155-159)			
	6.5	July 95			
	6.6	"	March 00		
	6.7	"	Oct. 97		
	6.8	"			
	6.8	Jan. 96 (only ser.no. 5E155-159)			
	6.9	July 95			
7	7.1	"	Oct. 97	May 08	Juli 19
	7.2	"			
	7.3	"			
	7.4	"			
	7.5	"	Febr. 04		
	7.5a	"	Febr. 04		
	7.6	"	March 00	Jan. 01	
	7.7	"			
	7.8	"	May 08		
	7.9	"	Oct. 97		
	7.10	"	Oct. 97	Juli 19	
8	8.1	"			
	8.2	"	Jan. 01		
	8.3	"			
	8.4	"			
	8.5	"			
9	9.1	July 95	May 10		
	9.2	May 10			

0.3 Table of contents

	Section
General (a non-approved section)	1
Limitations (an approved section)	2
Emergency procedures (an approved section)	3
Normal procedures (an approved section)	4
Performance (a partly approved section)	5
Mass (weight) and balance (a non-approved section)	6
Sailplane and systems description (a non-approved section)	7
Sailplane handling, care and maintenance (a non-approved section)	8
Supplements	9

Section 1

1. General
  - 1.1 Introduction
  - 1.2 Certification basis
  - 1.3 Warnings, cautions and notes
  - 1.4 Descriptive data
  - 1.5 Three view drawing

### 1.1 Introduction

The sailplane flight manual has been prepared to provide pilots and instructors with information for the safe and efficient operation of the DG-500 ELAN ORION sailplane.

This manual includes the material required to be furnished to the pilot by JAR Part 22. It also contains supplemental data supplied by the sailplane manufacturer.

### 1.2 Certification basis

This type of glider has been approved by the Luftfahrt-Bundesamt (LBA) in accordance with:

JAR Part 22 sailplanes and powered sailplanes Change 4, issued 7th May, 1987, including amendments 22/90/1, 22/91/1 and 22/92/1.

The Type Certificate No. 348 for the model DG-500 ELAN ORION was issued November 10, 1995.

Category of Airworthiness: "Utility" or "Aerobatic" with 17.2 m and 18 m wingspan without waterballast and if equipped properly.

### 1.3 Warnings, cautions and notes

The following definitions apply to warnings, cautions and notes used in the flight manual.

**Warning:** means that the non observation of the corresponding procedure leads to an immediate or important degradation of the flight safety.

**Caution:** means that the non observation of the corresponding procedure leads to a minor or to a more or less long term degradation of the flight safety.

**Note:** draws the attention on any special item not directly related to safety but which is important or unusual.

## 1.4 Descriptive data

The DG-500 ELAN ORION is a two-place high performance sailplane for training, performance flying and aerobatic training.

- wings in carbonfibre construction
- endplates for 17.2 m wingspan and wingtip extensions with winglet for 20 m span.
- 18 m winglets are optional.
- automatic hook ups for all controls
- comfortable seating and modern cockpit design similar to the DG-single seaters - safety cockpit
- large 2 piece canopy for very good inflight visibility
- draught free canopy demist and 1 adjustable swivel air vent for each pilot
- sealed airbrake- and landing gear box
- retractable main wheel, spring mounted
- nose wheel and tail wheel

## Technical data for all wingspans

length 6.86 m / 224 ft  
 height 1.82 m / 6.0 ft  
 waterballast 190 kg / 363 lbs  
 max. TOW 750 kg / 1653 lbs  
 VNE 270 km/h / 146 kts

## Technical data with 20 m span

wing span 20 m / 65.6 ft  
 wing surface 17.6 m<sup>2</sup> / 189 ft<sup>2</sup>  
 aspect ratio 22.7  
 empty weight with batteries and, min. inst. 410 kg / 904 lbs  
 wingloading W/S (payload 85 kg / 187 lbs) 28.1 kg/m<sup>2</sup> / 5.78 lbs/ft<sup>2</sup>  
 maximum W/S 42.6 kg/m<sup>2</sup> / 8.72 lbs/ft<sup>2</sup>  
 stall speed (W = 525 kg / 1157 lbs) 68 km/h / 36.7 kts  
 best L/D (W = 750 kg / 1653 lbs) at 110 km/h / 59 kts  
 min. sink (W = 625 kg / 1378 lbs) over 44  
 60 km/h / 32 kts 0.55 m/s / 149 ft/min.

## Technical data with 18 m span

wing span 18 m / 59.1 ft  
 wing surface 16.6 m<sup>2</sup> / 178.7 ft<sup>2</sup>  
 aspect ratio 19.5  
 empty weight with batteries and, min. inst. 400 kg / 882 lbs  
 wingloading W/S (payload 85 kg / 187 lbs) 29.2 kg/m<sup>2</sup> / 5.98 lbs/ft<sup>2</sup>  
 maximum W/S 45.2 kg/m<sup>2</sup> / 9.26 lbs/ft<sup>2</sup>  
 stall speed (W = 525 kg / 1157 lbs) 69 km/h / 37.3 kts  
 best L/D (W = 750 kg / 1653 lbs) at 110 km/h / 59 kts  
 min. sink (W = 625 kg / 1378 lbs) over 40  
 80 km/h / 43 kts 0.65 m/s / 175 ft/min.

## Technical data with 17.2 m span

wing span 17.2 m / 56.4 ft  
 wing surface 16.2 m<sup>2</sup> / 174.8 ft<sup>2</sup>  
 aspect ratio 18.3  
 empty weight with batteries and, min. inst. 400 kg / 882 lbs  
 max. TOW for aerobatics 625 kg / 1378 lbs  
 wingloading W/S (payload 85 kg / 187 lbs) 29.9 kg/m<sup>2</sup> / 6.13 lbs/ft<sup>2</sup>  
 stall speed (W = 525 kg / 1157 lbs) 70 km/h / 38.0 kts

A system with 2 fin ballast tanks is optional.  
 Tank A) to compensate the the C.G. shift due to wing water ballast, max. 6.6 kg.  
 Tank B) to compensate the mass of the rear pilot, max. 12.3 kg.

When dumping the wing tanks only tank A) will be emptied, the compensation of the rear pilot's mass remains even when flying without wing ballast. Tank B can only be emptied on the ground via the filling hose. For a detailed description refer to sect. 7.10.2.

Issued: July 1995

1.4

## 1.5

## 3 view drawing

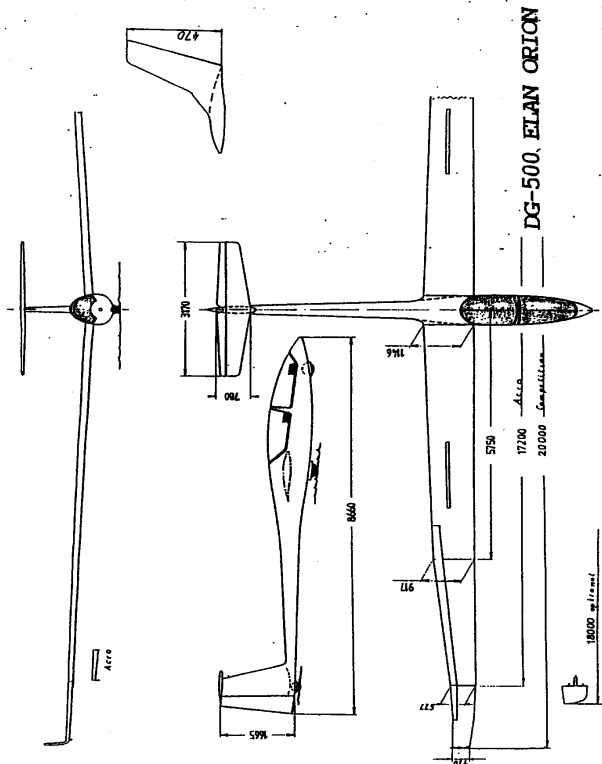

Issued: July 1995

1.5



Section 2

- 2. Limitations
- 2.1 Introduction
- 2.2 Airspeed
- 2.3 Airspeed Indicator Markings
- 2.4 Section not effective
- 2.5 Section not effective
- 2.6 Section not effective
- 2.7 Weight
- 2.8 Center of Gravity
- 2.9 Approved manoeuvres
- 2.10 Manoeuvring load factors
- 2.11 Flight crew
- 2.12. Kinds of operation
- 2.13 Minimum equipment
- 2.14 Aerotow and Winch- and Autotow - launching
  - 2.14.1 Weak links
  - 2.14.2 Towing cable
  - 2.14.3 Max. towing speeds
  - 2.14.4 Tow Release
- 2.15 Cross wind
- 2.16 Tyre pressure
- 2.17 Water ballast
- 2.18 Fin water ballast (Option)
- 2.19 Limitations Placards

2.1 Introduction

Section 2 includes operating limitations, instrument markings and basic placards necessary for safe operation of the sailplane, its standard systems and standard equipment.

The limitations included in this section have been approved by the LBA.

## 2.2 Airspeed

Airspeed limitations and their operational significance are shown below:

	Speed	(IAS) km/h(kts)	Remarks
VNE	Never exceed speed	270 (146)	Do not exceed this speed in any operation and do not use more than 1/3 of control deflection.
VRA	Rough air speed	190 (103)	Do not exceed this speed except in smooth air and then only with caution. Rough air is in lee-wave rotor, thunderclouds etc.
VA	Manoeuvring speed	190 (103)	Do not make full or abrupt control movement above this speed, because under certain condition the sailplane may be overstressed by full control movement.
VW	Maximum winch-launching speed	140 (76)	Do not exceed this speed during winch- or auto-tow-launching
VT	Maximum aero-towing speed	190 (103)	Do not exceed this speed during aerotowing
VLO	Maximum landing gear operating speed	190 (103)	Do not extend or retract the landing gear above this speed

**Warning:** At higher altitudes the true airspeed is higher than the indicated airspeed, so VNE is reduced with altitude see sect. 4.5.9.

## 2.3 Airspeed Indicator Markings

Airspeed indicator markings and their colour code significance are shown below:

Marking	(IAS) value or range km/h	(kts)	Significance
Green Arc	90 - 190 (48.5 - 103)		<b>Normal Operating Range</b> (Lower limit is maximum weight 1.1 VS1 at most forward C.G. Upper limit is rough air speed.)
Yellow Arc	190 - 270 (103 - 146)		Manoeuvres must be conducted with caution and only in smooth air.
Red Line	270 (146)		Maximum speed for all operations.
Yellow Triangle	100 (54)		Approach speed at maximum weight

2.7 Mass (weight)

- A) Category Aerobatic  
 Maximum Take-off mass: 625 kg, 1378 lbs.  
 Maximum landing mass: 625 kg, 1378 lbs.
- B) Category Utility  
 Maximum Take-Off mass: 750 kg, 1653 lbs.  
 Maximum landing mass: 750 kg, 1653 lbs.  
 Maximum mass of all  
 non lifting parts = 445 kg (981 lbs.)

Maximum mass in baggage compartment = 15 kg (33 lbs.)

Caution: Heavy pieces of baggage must be secured to the baggage compartment floor (screwing to the floor or with belts). The max. mass secured on one half of the floor (left and right of fuselage centre line) should not exceed 7,5 kg (16.5 lbs.).

Warning: Follow the loading procedures see sect. 6.

2.8 Center of gravity

Center of gravity range in flight is

185 mm (7.28 in.) up to 480 mm (18.9 in.) behind datum.

datum = wing leading edge at the rootrib

reference line = aft fuselage centre line horizontal  
 C.G. diagrams and loading chart see sect.6.

Warning: Flying is only allowed with the battery Z 07 installed in the fin as otherwise the forward C.G. limit may be exceeded. A suitable weight of 4.3 kg (9.5 lbs.) may be used instead of a battery.

2.9 Approved manoeuvres /

**Airworthiness category "Utility":**

This sailplane is certified for normal gliding and simple aerobatics. Aerobatics is approved only without water ballast in the wing tanks (and fin tank A). The following aerobatic manoeuvres are approved for all wingspan.

Manoeuvre	recommended entry speed IAS	
	km/h	kts.
Spins	/	/
Inside Loop	200	108
Stall Turn	200	108
Lazy Eight	200	108
Chandelle	200	108

## Flight manual DG-500 ELAN ORION

### Approved manoeuvres Category Aerobatic:

(wingspans 17.2 m and 18 m, only without water ballast in the wing tanks (and fin tank A))

All manoeuvres approved for category Utility and:

Inverted flight	recommended speed 140-200 km/h (76-108 kts.)
	recommended entry speeds
Slow roll	180-200 km/h (97-108 kts.)
Half roll and half loop	170-180 km/h (92-97 kts.)
Half loop and half roll	220 km/h (119 kts.)

### 2.10 Manoeuvring load factors

The following load factors must not be exceeded:

Airworthiness category:	Utility	Aerobatic
at manoeuvring speed	VA + 5.3 -2.65	+7.0 -5.0
at max. speed	VNE + 4.0 -1.5	+7.0 -5.0
airbrakes extended	VNE + 3.5	

### 2.11 Flight crew

a) single seated

max. load in the front seat 110 kg 242 lbs.

min. load in the front seat see placard in cockpit and weighing report page 6.5

b) two seated

max. cockpit load is 210 kg (463 lbs.) with a max. of 105 kg (231 lbs.) in the front seat or 110 kg (242 lbs.) in the front seat and 90 kg (198 lbs.) in the rear seat.

min. cockpit load in the front seat is the min. cockpit load see a) minus 40% of the load in the rear seat. This means that 10 kg (22 lbs.) in the rear seat replaces 4 kg (8.8 lbs.) missing cockpit load in the front seat.

With these loads, the C.G. range given under 2.8 will be kept in the limits if the empty weight C.G. is in its limits. see loading chart in sect. 6.

Either the front seat or the rear seat may designated as seat of the pilot in command.

If the rear seat is to be designated it must be assured that all necessary operating items and instruments are installed and that the pilot in command has sufficient training in flying safely from the rear seat.

**Caution:** With lower pilot weights lead ballast must be added to the seat. Ballast put on the seat (lead ballast cushion) must be fastened at the safety belt anchorage points. Installation for removable trim ballast see sect. 7.16.1.

**Note:** For Australia the lower limit for the min. load in the cockpit should not exceed 66 kg (146 lbs.). A provision for removable ballast see sect. 7.16.1 is mandatory.

## Flight manual DG-500 ELAN ORION

### 2.12 Kinds of operation

#### A) All configurations

Flights according to VFR (daylight)

Aerotow

Winch- and auto-launching

#### B) In addition when flying without waterballast

1. Cloud flying (daylight): permitted when properly instrumented (see below).
2. Simple aerobatics see sect 4.5.12. (Category Utility)
3. Aerobatics see section 4.5.12. (Category Aerobatic) if the required equipment (see below ) is installed, only with 17,2 m and 18 m span.

**Note:** Cloud flying is not permitted in the USA, Canada and Australia.

### 2.13 Minimum equipment

As minimum equipment only the instruments and equipment specified in the equipment list (see maintenance manual) are admissible.

**Note:** The actual equipment list is filed in the enclosures of the maintenance manual.

#### a) Normal operation

**Airspeed indicator:** Range: 0-300 km/h (0-165kts.); Speed range markings see sect. 2.3

**Altimeter:** Altimeter with fine range pointer, 1 turn max. 1000 m (3000 ft.)

**Four piece symmetrical safety harness**

**VHF - transceiver** (ready for operation)

**Battery Z07** or a ballast weight of 4,3 kg (9.5 lbs.) installed in the battery box in the fin

**Parachute** automatic or manual type or a suitable firm back cushion approximately 8 cm ( 3 in.) thick

**Required placards, check lists and this Flight manual.**

**With optional fin waterballast tanks:**

**Outside air temperature gauge** with probe in the fuselage nose with blue marking for temperatures below 2°C, (36°F).

#### b) In addition for cloud flying

(Not permitted in the USA, Canada and Australia)

**Variometer**

**Turn and bank indicator**

**Remark:** Experience has shown that the installed airspeed indicator system may be used for cloud flying.

#### c) In addition for aerobatics (Category Aerobatic)

**Accelerometer** capable of retaining max. and min. g-values with markings red radial lines at +7 g and -5 g.

2.14 **Aerotow, winch and autotow launching**

2.14.1 **Weak links**

10 000 N + 10%  
2 200 lbs. + 10%

2.14.2 **Length of the towing cable**

for aerotow 30-70 m (100 - 230 ft)

Material: hemp- or plastic fibres

2.14.3 **Max. towing speeds**

Aerotow VT = 190 km/h, 103 kts.  
Winch- and autotow VW = 140 km/h, 76 kts.

2.14.4 **Tow Release**

The C.G. tow release (installed in front of the main wheel) is suitable only for winch- and auto launching.

The nose hook is to be used only for aerotow.

2.14.5 **Winch launching with fin tanks (option) filled**

is prohibited if the tail-wheel does not rest on the ground at the beginning of the launch.

**Note:** If the tail-wheel doesn't stay on the ground by itself, press down the tail at the horizontal tail-plane from behind and hold it in this position.

2.15 **Crosswinds**

The maximum crosswind component according to the airworthiness requirements for take-off and landing is 15 km/h (8 kts).

2.16 **Tyre Pressure**

Main wheel	2.5 bar	36	psi
Nose wheel	2.5 bar	36	psi
Tail wheel	4 bar	58	psi

2.17 **Water ballast in the wing tanks**

Only symmetrical loading is allowed.

After filling balance the wings by dumping enough water from the heavy wing.

It is not allowed to fly with leaking watertanks, as this may result in asymmetrical loading condition.

Follow the loading chart, see sect. 6.8.

Max. capacity 80 l (21.2 US gal.) per wing.

2.18 **Water ballast in the fin tank (Option)**

As it is dangerous to fly with empty wing tanks while ballast is resting in the fin, it is prohibited to fill water into the fin tank if there is any risk of icing. The flight conditions must comply with the following table.

min. ground	°C	13,5	17	24	31	38
temperature	°F	56	63	75	88	100
max. flight	m	1500	2000	3000	4000	5000
altitude	ft	5000	6500	10000	13000	16500

In addition the outside air temperature gauge is to be watched. The OAT should not be lower than 2° C (36° F).

2.19 Limitations placards

<b>ELAN FLIGHT - Slovenska</b>		
Type: DG - 500 ELAN Orion	Year of construction:	
Serial No. <u>155</u>	<u>X</u>	
Maximum airspeeds	km-h	kts
Winch launch	140	76
Aero - tow	190	102
Manoeuvring V <sub>A</sub>	190	102
Rough air	190	102
Landing gear operating	190	102
Maximum speed V <sub>NE</sub>	270	146
Approved aerobatic manoeuvres (category utility U): pos. Loop, Stall Turn, Chandelle, Spin in addition category A:		
Spans 17.2 or 18 m, only without waterballast half loop and half roll, half roll and half loop, slow roll, inverted flight.		

Maximum mass: 625 kg (1378 lbs.) Category A			
730 kg (1653 lbs.) Category U			
Loading chart			
Cockpit load: (parachute included)	front seat	rear seat	
maximum	110 kg	242 lbs	90 kg 198 lbs
or maximum	105 kg	231 lbs	105 kg 231 lbs
	kg	lbs	

Cockpit Check

1. Lead ballast ( for under weight pilot)?
2. Parachute worn properly?
3. Safety harness buckled?
4. Front seat : pedals adjusted?  
Rear seat: seat height adjusted?
5. All controls and knobs in reach?
6. Altimeter?
7. Dive brakes cycled and locked?
8. Positive control check?  
(One person at the control surfaces)
9. Fin ballast tanks emptied or correct amount filled in?
10. Trim?
11. Both canopies locked?

limits for use of the fin waterballast tank						
minimum	°C	13,5	17	24	31	38
ground temperature	°F	56	63	75	88	100
maximum	m	1500	2000	3000	4000	5000
flight/altitude	ft.	5000	6500	10000	13000	16500

Other cockpit placards see sect. 7.

with optional fin tanks

Fin ballast tank B		Minimum cockpit load	
kg	lbs	kg	lbs
Tank empty		Tank filled	

113 kts

Gepäck max. 15kg  
Baggage max.33lbs.

Sollbruchstelle 10000 N  
Rated load 2200 lbs.

Alt. m	0-2000	3000	4000	5000	6000
VNE Km/h	270	296	243	230	218
Alt. ft	0-6500	10000	13000	16000	20000
VNE Kts	146	138	131	124	117

Reifendruck 2,5 bar  
Tyre pressure 36 psi

nose wheel

Reifendruck 3 bar  
Tyre pressure 44 psi

main wheel

Reifendruck 4 bar  
Tyre pressure 58 psi

tail wheel

Section 3

3. Emergency procedures

3.1 Introduction

3.2 Canopy jettison

3.3. Bailing out

3.4 Stall recovery

3.5 Spin recovery

3.6 Spiral dive recovery

3.7 Recovery from unintentional cloud flying

3.8 Flight with asymmetric water ballast

3.9 Emergency wheel up landing

3.10 Ground loop

3.11 Emergency landing in water

## Flight manual DG-500 ELAN ORION

### 3.1 Introduction

Section 3 provides a checklist and amplification for coping with emergencies that may occur. Emergency situations can be minimized by proper pre-flight inspections and maintenance.

**Caution:** Canopy jettison and bailing out should be trained several times on the ground before flying the aircraft.

### 3.2 Canopy jettison

To bail out the white-red canopy opening handle (left) has to be operated with your right hand. Open the canopy as far as possible.

If the canopy doesn't stay open (or is not blown away by the oncoming air), but is closed by the air pressure, you have to release the canopy in its closed position by operating the red emergency release handle (right) with your left hand, then push the canopy upwards.

The retaining lines will tear off.

The gas struts (if installed) will disengage automatically

### 3.3 Bailing out

First jettison both canopies, then open the safety harness and bail out. The low walls of the front cockpit allow for a quick push-off exit.

### 3.4 Stall recovery

Easing the stick forward and picking up a dropping wing with sufficient opposite rudder the glider can be recovered from the stall.

To recognize and prevent the stall, please refer to sect. 4.5.4.

### 3.5 Spin Recovery

Apply full opposite rudder against direction of the spin, pause.

Then ease stick forward until the rotation ceases, centralize the controls and carefully pull out of the dive.

The ailerons should be kept neutral during recovery.

**Caution:** To prevent unintentional spinning do not stall the sailplane. Fly with enough speed reserve especially in gusty conditions and in the landing pattern.

Intended spins with waterballast are not permitted.

Height loss during recovery	up to.	50 - 100 m (160-330 ft)
max. speed during recovery		200 km/h (108 kts.)



## Flight manual DG-500 ELAN ORION

### 3.6 **Spiral dive recovery**

Apply rudder and aileron in opposite direction and carefully pull out of the dive.

Spiral dive occurs only when spinning more than 3 turns with medium C.G. positions, see sect. 4.5.12.

To prevent spiral dives intentional spinning should only be executed at aft C.G. positions.

Recovery from unintentional spinning should be done immediately.

### 3.7 **Recovery from unintentional cloud flying**

Spins are not to be used to loose altitude. In an emergency, pull out the dive brakes fully before exceeding a speed of 200 km/h and fly with max. 200 km/h (108 kts.) until leaving the cloud.

At higher speeds up to VNE, pull out the dive brakes very carefully because of high aerodynamic and g-loads.

### 3.8 **Flight with asymmetric waterballast**

If you suspect that the waterballast does not dump symmetrically you have to close the dump valves of the wingtanks immediately, to avoid greater asymmetry.

Asymmetry can be verified by the necessary aileron deflection in straight flight at low airspeeds.

When flying with asymmetric waterballast you have to increase the airspeed, especially in turns, so that you can avoid a stall at all costs.

If the aircraft does enter a spin, you have to push the stick forward clearly during recovery.

Fly the landing pattern and touch down approx. 10 km/h (6 kts.) faster than usually and after touch down control carefully the bank angle to avoid the wing touching the ground too early.

### 3.9 **Emergency wheel up landing**

It is not recommended to execute a wheel up emergency landing, as the energy absorption capability of the fuselage is much smaller than that of the landing gear.

If the landing gear can't be extended touch down with small angle of attack.

## Flight manual DG-500 ELAN ORION

### 3.10 **Emergency ground loop**

If there is the risk of overshooting the landing strip you have to decide at least 40 m (130 ft) before the end of the field to execute a controlled ground loop.

If possible turn into the wind, lift the tail by pushing the stick forward.

### 3.11 **Emergency landing on water**

From the experience with emergency water landing we know, that it is likely that the sailplane will dive into the water, cockpit first.

Therefore an emergency landing on water should be the last choice. In the case of a water landing, however, extend the landing gear.

Recommended procedures:

On downwind leg of the landing pattern: Extend the landing gear, unlock the parachute harness (not the seat harness)

Touch down: With landing gear extended and airspeed as low as possible.

At point of touch-down: Use your left arm to protect your face against possible canopy fracture.

After touch down: Unfasten seat belt harnesses and undo parachute.

Leaving the cockpit under water: If the canopy has not fractured, opening the canopy may be possible only after the forward fuselage is almost completely filled with water.

# Flight manual DG-500 ELAN ORION

## Section 4

- 4. Normal procedures
  - 4.1 Introduction
  - 4.2 Rigging and derigging, filling the watertanks
    - 4.2.1 Rigging
    - 4.2.2 Filling the wing watertanks
    - 4.2.3 Filling the fin tank A (Option)
    - 4.2.4 Filling the fin tank B
    - 4.2.5 Derigging
  - 4.3 Daily Inspection
  - 4.4 Pre-flight Inspection
  - 4.5 Normal procedures and recommended speeds
    - 4.5.1 Section not effective
    - 4.5.2 Section not effective
    - 4.5.3 Launch
    - 4.5.4 Free flight
    - 4.5.5 Section not effective
    - 4.5.6 Section not effective
    - 4.5.7 Approach and landing
    - 4.5.8 Flight with waterballast
    - 4.5.9 Flight at high altitude and at low temperatures
    - 4.5.10 Flight in rain and thunderstorms
    - 4.5.11 Cloud flying
    - 4.5.12 Aerobatics

4.1 Introduction

Section 4 provides checklist and amplified procedures for the conduct of normal operation. Normal procedures associated with optional systems can be found in section 9.

4.2 Rigging and derigging, filling the watertanks

4.2.1 Rigging

1. Open the rear canopy.
2. Clean and lube the pins, bushings and the control connections.
3. Rigging the inboard wing panels.  
All controls hook up automatically. Therefore set the wing flap handle into zero position and the airbrake handle to the forward stop. The airbrakes must be locked. Screw one of the rear wing securing pins on the tool W 38/2. Close the rear canopy. Push the right wing panel into place. Insert the rear securing pin with the tool at the rear attachment fitting. Push in the tool so far that the upper surface of the brass part of the tool is flush with the wing surface. Screw off the tool. Check if the locking device for the securing pin has engaged. Screw the other securing pin on to the tool. Open the rear canopy. Push in the left wing. Mount and check the left securing pin by the same method as the right side. Push in the two main pins as far as possible. Place the handles horizontal or upright. Release the wings. Finally screw in the securing screws in the main pins. When the screws are fastened press the handles of the screws into the clips at the main pin handles.
4. Rigging of the stabilizer  
Check if the battery is installed in the fin and is connected. Operating the glider without the battery or without a ballast weight of 4.3 kg (9.5 lbs.) is not permitted as the forward C.G. limit may be exceeded.  
Set the trim nose down.  
Screw the tool W 38/2 into the securing plate (near the top of the left surface of the fin). Pull out the securing plate with the tool, move it downwards to engage in the rigging position.

4. ff. Set the stabilizer on, so that the roller at the fuselage side push rod is inserted into the funnel at the elevator.

Watch carefully the procedure.

When the stabilizer is set down and laying on the fin, push it aft. The roller will slide forward in the funnel if you hold the elevator in the pertinent position.

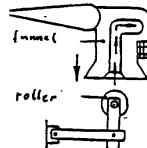

Release the securing device by pulling out with the tool and engage the securing device by lifting the tool. The securing plate must be flush with the surface of the fin. Screw out the tool.

Check for correct elevator connection by looking from the rear into the gap at the right hand side of the rudder.

5. Rigging and derigging the endplates for 17.2 m span

The endplates are to be fixed to the wings with 2 flathead screws M10 x 40 DIN 7991-8.8 zn. The screws must therefore be inserted into the front and rear lift pin bushes and to be fastened with a 6 mm Allen key.

6. Rigging and derigging the wing tip extensions and of the 18 m tips (Option)

1. Insert the wing tip extensions into the wing. Press in the locking pin with your finger. Insert the wing tip so far that the aileron connectors starts to slide into the flaperon slots. Strike firmly with the palm of your hand on to the wing tip to lock in the wing tip extension.
2. Disassembling of the wing tip  
Use a 6 mm diameter pin for pressing in the locking pin on the wings upper side.

7. Tape the gaps of the wing-fuselage junction.
8. Positive control check.

## 4.2.2 Filling the wing water ballast tanks

With an optional fin tank first push forward the handle for the fin tank.  
To fill the water ballast, pull back the respective handle (top-right tank, bottom-left tank) in the cockpit.

Place one wingtip on the ground. Attach the hose supplied with your glider in the water outlet on the lower surface of the wing.

**Warning:** Fill the hose from your water containers but never from a mains pressure water supply. Filling the wing tanks with excessive pressure (more than 0.2 bar, 3 psi) will definitely burst the wing shell!

**Caution:** If the tanks are to be filled up completely you must suck the air out of the tanks with the filling hose.

Fill with the desired amount of water regarding the loading chart see sect. 6. After filling close the valve with the water ballast handle and remove the hose. Place the other wingtip on the ground and fill the other tank.

In case a valve leaks slightly, you may try to pull out the PVC pushrod of the valve to stop the leak. If this cannot be done successfully refer to maintenance manual 1.8.2. and 4.1.

It is not allowed to fly with leaking watertanks, as this may result in asymmetrical loading condition. After filling the tanks, check to see if the wings are balanced. If one wing is heavier, dump enough water to balance the wings.

4.2.3 Filling the fin waterballast tanks (Option)  
Wing ballast compensation tank (Tank A)

- a) This tank must be filled after filling the wingtanks.

Determine the amount see sect. 6.8.5a).  
Connect the transparent funnel equipped filling hose (supplied with the aircraft) via the hose connector GRS 10-12 to the hose which comes out of the left rear end of the fuselage. The funnel can be suspended at the top of the rudder.

Fill with clean water using a graduated measuring vessel.

In addition, the loaded quantity can be checked by holding the filling hose to the scale at the fin (communicating tube).

After filling, close the fin tank dump lever. Then remove the filling hose with the hose connector.

## b) Rear Pilot mass compensation tank (Tank B)

Connect the short hose with nipple to the hose connector of the funnel equipped filling hose which is also used for filling Tank A.

Determine the amount see sect. 6.8.5a).

Rotate the coupling out of the lower side of the fuselage (in front of the tailwheel). To rotate the coupling press upwards the forward end of the cover.

Move upwards the cap ring of the coupling and plug in the nipple into the coupling. The funnel can be suspended at the top of the rudder.

Fill with clean water using a graduated measuring vessel.

In addition, the loaded quantity can be checked by holding the filling hose to the scale at the fin (communicating tube).

After filling remove the nipple. The coupling closes automatically. Check to see if the control light in the front instrument panel displays "tank filled". The "tank empty" light must be off.

## 4.2.4 Draining the fin tank B

Rotate the coupling out of the lower side of the fuselage, same as for filling the tank. Plug in the nipple with the short hose (without the long hose with funnel) into the coupling. Let the water drain out of the tank.

## 4.2.5 Derigging

Derigging follows the reverse of rigging. Water ballast in the wings must first be emptied. Lock the airbrakes.

For disassembling the wing securing pins the tool W 38/2 must be screwed into the bolt completely.

The brass part of the tool will then disengage this bolt.

It is recommended to leave the securing bolt in the right wing while you derig the left wing.

#### 4.3 Daily Inspection

Please keep in mind the importance of the inspection after rigging the glider and respectively each day prior to the first take off. It is for your safety.

**Caution:** After a heavy landing or if other high loads have been subjected to your sailplane, you must execute a complete inspection referring to maintenance manual sect. 2.3 prior to the next take off. If you detect any damage, don't operate your aircraft before the damage is repaired. If the maintenance- and repair manual don't give adequate information, please contact the manufacturer.

##### A Inspection prior to rigging

1. Wing roots and spar ends
  - a) check for cracks, delamination etc.
  - b) check the bushes and their glued connection in root ribs and the spar ends for wear
  - c) check the control hook ups at the rootrib for wear and corrosion
  - d) check the strings which hold the waterbags for sufficient tension (see maintenance manual sect. 4.1)
2. Fuselage at wing connection
  - a) check the lift pins for wear and corrosion
  - b) check the control hook ups including the water-dumpsystem for wear and corrosion
3. Top of the vertical fin
  - a) check the mounting points of the horizontal tailplane and the elevator control hook up for wear and corrosion
  - b) check if the battery is installed in the fin and connected
4. Horizontal tailplane  
check the mounting points and the elevator control hook up for wear and corrosion
5. Rigging points for the outboard wing panels  
Check the lift pins and bushes for wear and corrosion and check their glued connections.  
Check the securing pin for function and enough spring force.

## ORION B Inspection after rigging

### Walk around the aircraft

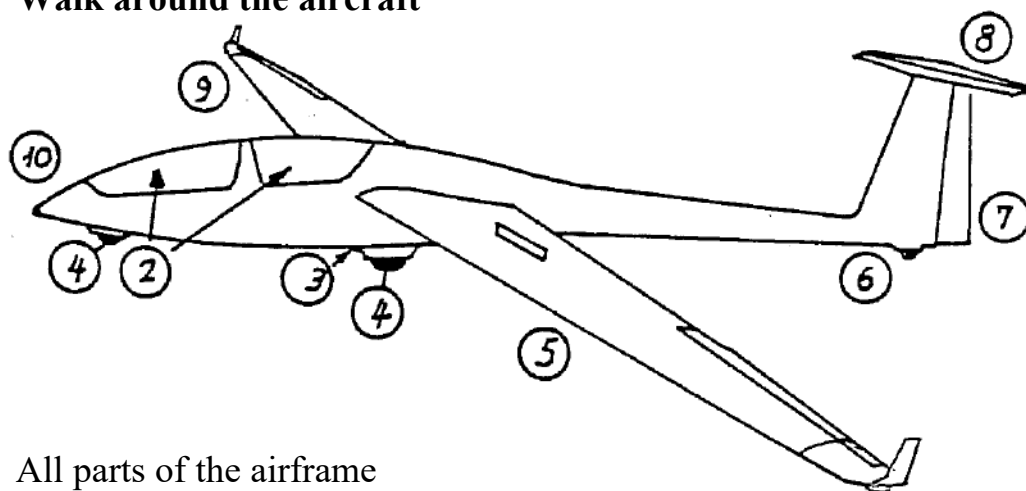

1. All parts of the airframe
  - a) check for flaws such as bubbles, holes, bumps and cracks in the surface
  - b) check leading and trailing edges of the wings and control surfaces for cracks
2. Cockpit area
  - a) check the canopy locking mechanism
  - b) check the canopy emergency release see sect. 7.15 (not each day, but min. every 3 month)
  - c) check the main pin securing
  - d) check the securing ropes of the headrest in the rear cockpit for wear function and length: is it possible that the headrest interferes with the control stick?
  - e) check all controls for wear and function, incl. positive control check
  - f) check the tow release system for wear and function incl. cable release check
  - g) check for foreign objects
  - h) check the instrumentation and radio for wear and function
  - i) check the radio and other electrical equipment for function. If there is no electric power it must be assumed, that the battery is not installed in the fin. **Flying is only allowed with the battery in the fin as otherwise the forward C.G. limit may be exceeded.**
  - j) check the brake fluid level
  - k) check at front and rear canopy if the end of the rear locking rod doesn't protrude over the canopy frame contour with opening mechanism in fully open position.  
If the rod protrudes over the contour proceed with instruction 3 of TN 1000/42.
  - l) Option Canopy warning: Check if with front canopy locked and rear canopy open a warning burr appears. If not you have to exchange the battery, see section 7.16.5.

## Flight manual DG-500 ELAN ORION

3. C.G. Tow hook
  - a) check the ring muzzle of the C.G. hook for wear and function
  - b) check for cleanliness and corrosion
4. Main landing gear and nose wheel
  - a) check the struts, the gear box, the gear doors and the tyre for wear; dirt in the struts can hinder the landing gear from locking over center the next time!
  - b) check the tyre pressure  
mainwheel: 3.0 bar - 44 psi  
nose wheel: 2.5 bar - 36 psi
  - c) check wheel brake and cable for wear and function
5. Left wing
  - a) check locking of the outboard wing or screwed joint of the end plate
  - b) check the aileron for excessive free play
  - c) check airbrake- and box and control rod for wear and free play. It must be possible to retract the airbrake, even if it is pressed in backward direction. If there is any water in the airbrake box this has to be removed.
  - d) check the locking of the rear wing attachment pin
6. Tail wheel
  - a) check for wear, free play and excessive dirt in the wheel box. Remove excessive dirt prior to take off!
  - b) check tyre pressure: 4 bar -58 psi
7. Rear end of the fuselage
  - a) check the lower rudder hinge and the connection of the rudder cables for wear, free play and correct securing
  - b) check the bulkhead and fin trailing edge shear web for cracks and delamination
8. Fin - horizontal tail
  - a) check the upper rudder hinge for wear and free play
  - b) check the elevator for free play and correct control hook up, look from the rear into the gap at the right hand side of the rudder
  - c) check the securing of the stabilizer
  - d) check the horizontal tail for free play
  - e) check the TE or Multiprobe for correct insertion
9. Right wing see detail 5.
10. Fuselage nose
  - a) check the ports for the static pressure and the pitot pressure for cleanliness.
  - b) if the sailplane was parked in rain, you have to empty the static ports by sucking out the water at the ports.
  - c) check the nose hook for cleanness and corrosion



#### 4.4 Preflight inspection

1. Lead ballast (for under weight pilot)?
2. Parachute worn properly?
3. Safety harness buckled?
4. Front seat: pedals adjusted?  
Rear seat: seating height adjusted?
5. All controls and knobs in reach?
6. Altimeter?
7. Dive brakes cycled and locked?
8. Positive control check? (One person at the control surfaces).
9. Fin ballast tanks emptied or correct amount filled?
10. Trim?
11. Both canopies locked?

## 4.5 Normal procedures and and recommended speeds

## 4.5.3 Launch

Due to the towhook position being in the middle of the fuselage and the excellent effectiveness of the ailerons and rudder, the possibility of wing dropping or ground loops, even on a slow starting aerotow is reduced. Take-off with strong crosswind is possible.

**Aerotow**

- a) Aerotow is permitted only using the nose tow release. Set trim to neutral for aerotow.
- b) Pull the stick until the nose wheel lifts off from the ground. Then control the airplane so that nose wheel and tail wheel don't touch the ground. Don't try to lift off before you reach an airspeed of 80 km/h (43 kts) (without ballast).  
On a rough airfield hold the control stick tight. The undercarriage can be retracted at safety height during the tow.

Normal towing speed is 120-130 km/h  
(65 - 70 kts).

For a cross country tow the speed can be as high as 190 km/h (103 kts).

**Warning:** Aerotow with high take off weight requires a powerful tow plane. Many tow planes are not certified to tow gliders with high take off weights. Reduce the take off weight if necessary!

**Winch launch** (only allowed at the C.G. release)

Set the trim fully nose down for winch launch. To accomplish this, operate trimmer lever on the control column and push the control knob on the left cockpit wall to its forwardmost position.

**Caution:** During ground roll and initial take-off (especially when flying solo) push the control stick to its forwardmost position or fully nose-down to prevent excessive nose up pitching rotation during initial take-off.

After reaching safety altitude gradually pull back the stick, so that the glider will not pick up excessive speed. Don't pull too hard.

After reaching release altitude pull the tow release knob.

Recommended winch launch airspeed 110-120 km/h  
(60-65 kts).

**Caution:** Do not fly at less than 90 km/h (49kts) or not more than 140 km/h (76 kts).

**Caution:**

To avoid a strong impact at the tail-wheel due to surging of the winch cable the tail-wheel should rest on the ground at the beginning of the winch launch. If the tail-wheel doesn't stay on the ground by itself, it is recommended to press down the tail at the horizontal tail-plane from behind and hold it in this position.

**Warning:** Winch launch with high take off weight requires a powerful winch!

#### 4.5.4 Free flight

##### Stalling characteristics (level and turning flight)

When stalled the DG-500 ELAN ORION will continue to fly level with high sink rate and buffeting. If the stick is pulled further the DG-500 ELAN ORION will drop the nose or drop one wing. During the stall a large angle of attack will be reached.

At forward C.G. positions the DG-500 ELAN ORION can be flown in stall without wing or nose dropping. When reaching the minimum speed, the angle of attack has to be increased significantly before the DG-500 ELAN ORION stalls. Therefore stalled flight is easy to recognize.

With stick forward and opposite rudder if required the DG-500 ELAN ORION can be recovered without much loss of height. Rain does not influence this behaviour noticeably. The loss of height is ca. 30 m. Stall airspeeds see sect. 5.2.2.

##### Caution

Flight in conditions conducive to lightning strikes must be avoided.

#### 4.5.7 Approach and landing

Abeam the landing point extend the landing gear (Option).  
In calm weather approach with approx. 100 km/h (54 kts). With strong wind fly faster!

The very effective Schempp-Hirth dive brakes make a short landing possible. A slip is therefore not necessary as a landing technique.

**Caution:** While slipping, the rudder is sucked in its displaced position. So it is recommended to practice slipping at a higher altitude.

Strong crosswind offers no problem.

Do not approach too slowly with fully extended airbrakes otherwise the aircraft may drop during flare out.

When flaring out keep the airbrake setting you were using, opening them further may drop the sailplane.

Clean the landing gear and tow release after landing in an muddy field. Dirt in the front strut (Option retractable landing gear) can keep the landing gear from locking over center next time. Simply hosing with water is the best cleaning method.

##### Landing with the landing gear retracted

Wheel up landing is not recommended see emergency procedures sect. 3.9..

After wheel up landing check the fuselage belly, the tow hook and the tow hook bulkheads for damage.

##### Landing with asymmetric waterballast

See emergency prodcedures sect. 3.8..

## 4.5.8 Flight with water ballast

**Wing tanks**

recommended ballast for smooth thermals:

rate of climb	ballast				
	m/s	ftm	kts	ltr.	U.S. gallo
below 1,5	300	3	3	none	
1,5-3	300-600	3-6	100	26	
more than 3	600	6		max. ballast	

Do not exceed the maximum gross weight when loading the water ballast.

The maximum quantity of water allowed is dependent on the empty weight and the cockpit load (see sect.6). In flight, the water drains at approx.0,5 ltr./sec. (1.1 lbs/sec).

**Fin water ballast tanks (Option)**

For optimal thermaling performance and handling water ballast in the fin tanks should be used to compensate the forward movement of C.G. due to the water ballast in the wings and due to the mass of the rear pilot. Please refer to sect. 6.

If there is the risk of freezing, dump all water before you reach freezing altitude, latest at +2°C, or descend to lower altitudes.

If you suspect a tank is leaking, dump all water immediately.

Water ballast raises the approach speed, so it is recommended to dump the waterballast before landing. Dump the ballast before an outlanding in any case.

**Filling the waterballast see sect. 4.2**

After filling level the wings and check if the dump valves are tight. It is not allowed to fly with leaking watertanks as this may result in an asymmetric loading condition.

**Dumping of the waterballast**

Open the fin tank handle first.

Then open both wing ballast tanks together. To avoid an asymmetric loading condition, do not empty one wing tank after the other.

**Valves leaking, servicing**

Please refer to the maintenance manual sect. 1.8 and 4.1.

## Flight manual DG-500 ELAN ORION

### 4.5.9 Flight at high altitude and at low temperatures

With temperatures below 0°C (32°F) for instance when wave flying or flying in winter, it is possible that the control circuits could become stiffer. Special care should be taken to ensure that there is no moisture on any section of the control circuits to minimize the possibility of freeze up. It could be advantageous to apply Vaseline along all the edges of the airbrake cover plates to minimize the possibility of freezing closed.

Apply the controls in short periods.  
It is not allowed to carry waterballast.

#### Caution:

1. At temperatures below -20°C (-4°F) there is the risk of cracking the gelcoat.
2. Attention must be paid to the fact that at higher altitudes the true airspeed is greater than the indicated airspeed.

The max. speed VNE is reduced. See the following table:

Altitude in Metres	0-2000	3000	4000	5000	6000
VNE IAS km/h	270	256	243	230	218

Altitude in ft.	0-6600	10000	13000	16000	20000
VNE IAS kts.	146	138	131	124	117

3. Dump the water ballast before you reach freezing altitude or descend to lower altitudes.
4. Do not fly below 0°C (32°F) when your glider is wet (e.g. after rain).

### 4.5.10 Flight in rain and thunderstorms

With light rain the stall speed and the sink rate increases slightly and the approach speed has to be increased.

**Warning:** Flights and especially winch launches in the vicinity of thunder storms should be avoided. Due to lightning discharge, carbon fibre structures may be destroyed.

### 4.5.11 Cloud flying

(only without waterballast and)

Take care to fly smoothly and coordinated. It is prohibited to use a spin as a method for losing altitude in the clouds. In case of emergency, pull out the dive brakes fully before exceeding a speed of 200 km/h and dive with max. 200 km/h (108 kts) to leave the cloud.

**Warning:** Flying in or near thunderstorm-clouds is prohibited.

## 4.5.12 Aerobatics ("Utility" Category)

Execute only the approved manoeuvres.

**Approved manoeuvres**

(Utility Airworthiness Category, all wing spans, no water ballast in the wings and fin tank A)

1. Spins
2. Inside Loop Entry Speed 200 km/h (108 kts.)
3. Stall turn Entry Speed 200 km/h (108 kts.)
4. Chandelle Entry Speed 200 km/h (108 kts.)
5. Lazy Eight Entry Speed 200 km/h (108 kts.)

**Spins:**

**Note:** Prolonged spinning is best at aft C.G. positions. To perform prolonged spinning with 2 persons on board it is recommended to compensate the weight of the second pilot using fin tank B see sect. 6.8.5.b).

It is not necessary to extend the dive brakes during spin recovery. The DG-500 ELAN ORION shows a very large nose down pitch after leaving the spin, so you have to flare out correspondingly.

With forward C.G. positions prolonged spinning is not possible. The DG-500 ELAN ORION will terminate the spin by itself after a certain number of turns dependent on the C.G. position. The nose down pitch and speed will be high so with these C.G. positions not more than 1 turn spins should be executed, to avoid high g-loads.

With medium C.G. positions there is a tendency that the spin will turn into a spiral dive after approx. 3 turns. Reaching this state you have to recover immediately.

With 20 m span the tendency for spiral dive can be reduced if the spin is induced by applying aileron and rudder in the direction of the spin. With the other wing spans spin with aileron neutral only.

**Inducing the spin:** (Normal procedure)

Gradually bring the sailplane into a stall. When it starts to burble, pull the stick back completely and kick in full rudder in the spin direction.

**Recovering from the spin:**

Apply full opposite rudder against direction of the spin, pause, then ease the stick forward until the rotation ceases, neutralize the controls and carefully pull out of the dive. The ailerons should be kept neutral during recovery.

Height loss during recovery is approx. 50-80 m (160-260 ft), the max. speed is max. 200 km/h (108 kts.).

**Stallturn.**

To fly a stallturn safely, please proceed as follows:

After reaching the entry speed pull back the stick quickly, but not abruptly. During the pull out, shortly before reaching the vertical flight path initiate rotation with the rudder. Push the rudder quickly, but not abruptly. Also, at the highest point of the turn, the glider should still have a positive airspeed above stalling speed.

Be careful not to exceed the airspeed for max. control surface deflection as indicated in section 2.2.

When reaching the vertical dive, flare out immediately to minimize speed increase and g-load.

**Caution:**

A classical stallturn with almost no airspeed at the highest point of the turn is very difficult to fly with a glider with larger wingspan, due to the high moment of inertia.

This effect is taken into account when using the above mentioned procedure.

**Warning:**

If the rudder is pushed too late and the rotation is insufficient, it is possible that the glider tailsides (falls tailwards).

If this happens, it is important to hold all controls firmly, preferably at one of the stops, until the nose swings down. Then flare out immediately.

**Aerobatics Category A, Aerobatic**

only with 17.2 m or 18 m span and without water ballast in the wings and fin tank A. Execute only the approved manoeuvres.

Don't execute aerobatics below the safety altitude required by national law.

**Approved manoeuvres (Aerobatic Category):**

All manoeuvres approved for Utility category and:

Inverted flight	recommended speed 140-200 km/h (76-108 kts.)
Slow roll	entry speeds 180-200 km/h (97-108 kts.)

Half roll and half loop	170-180 km/h (92-99 kts.)
Half loop and half roll	220 km/h (119 kts.)

**Caution:** The DG-500 ELAN ORION is a high performance sailplane. Therefore the speed increase in the dive, especially in inverted flight is high. Therefore training aerobatics should only be executed after a rating with an experienced pilot or if you can master the manoeuvres on other sailplane types.

In any case don't try to execute the manoeuvres with entry speeds other than those listed above.

**Inverted flight:**

The speed in inverted flight should preferably be chosen between 140-200 km/h (76-108 kts.). At speeds greater than 190 km/h (103 kts.) no full control deflections are allowed.

**Warning:** When the speed is reduced below the minimum speed (depending on weight and c.g. position 120 - 135 km/h, 65-73 kts.) the DG-500 ELAN ORION enters an inverted stationary stall with high sink-rate. This will be indicated by buffeting of the tailplane.

The aircraft nose may point far below the horizon and the airspeed may show 130 - 150 km/h (70 - 81 kts). The efficiency of the ailerons and rudder will be reduced considerably.

**Note:**

The inverted stalled flight must be recovered by neutralizing the stick until the buffeting of the tailplane stops. The airspeed will increase very quickly. As soon as this condition is reached, raise the glider nose above the horizon by gradually pushing the stick forward. Regain normal flight by a half roll.

## 4.5.12 cont.

**Half loop and half roll:**

After reaching the entry speed of 220 km/h (119 kts) pull the stick quickly, but not abruptly until reaching the inverted position, where the speed should still be 130 to 140 km/h (70-75 kts). Then return the stick to neutral and keep the nose slightly above the horizon. Then apply full aileron in the desired direction. After the wing passes the vertical position apply upper rudder to keep the nose above the horizon until normal flying position is reached.

**Note:**

If the nose is raised too much above the horizon or the inverted speed is too slow, a stall can occur when the wing reaches the vertical position and the glider finishes the rolling motion as a "flicked" roll into normal flying position.

**Half roll and half loop:**

After reaching the entry speed of 170-180 km/h (92-97 kts) the nose must be raised to 10 - 20° above the horizon. After returning the stick to neutral apply full aileron into the desired direction to start the half roll. After the wing passes vertical position the stick has to be pushed slightly (never abruptly) forward to keep the nose above the horizon. When reaching inverted flight the ailerons must be neutralized and the speed must be reduced to 130-140 km/h (70-76 kts) by pushing the stick forward before starting the half loop to level out.

**Note:**

If during the entry the nose is raised too high or the entry speed is too low, it could be that it is impossible to stop the rotation in the inverted position and the glider continues the roll into normal position.

4.5.12. cont.

**Slow roll:**

After reaching the entry speed of 180 - 200 km/h (97-108 kts) the nose must be raised slightly above the horizon. After returning the stick to neutral, full aileron has to be applied in the desired direction. After the wing has passed the first vertical position the stick is to be pushed slightly (never abruptly) forward to keep the nose above the horizon. When the wing passes the second vertical position the rudder must be applied upwards to keep the nose above the horizon until normal flying position is reached.

**Note:**

If during the inverted flight the nose is raised too high above the horizon and the speed is reduced too much a stall could occur when the wing reaches the second vertical position and the roll is finished as a "flicked"

The stall is indicated by buffeting of the tailplane.

Section 5

5. Performance

5.1 Introduction

5.2 Approved Data

5.2.1 Airspeed indicator system calibration

5.2.2 Stall speeds

5.3. Non approved further information

5.3.1 Demonstrated crosswind performance

5.3.2 Gliding performance

5.3.3 Flight Polar



5.1 Introduction

Section 5 provides approved data for airspeed calibration, stall speeds and non-approved further information.

The data in the charts has been computed from actual flight tests with the sailplane in good and clean condition and using average piloting techniques.

5.2 Approved data

5.2.1 Airspeed indicator system calibration

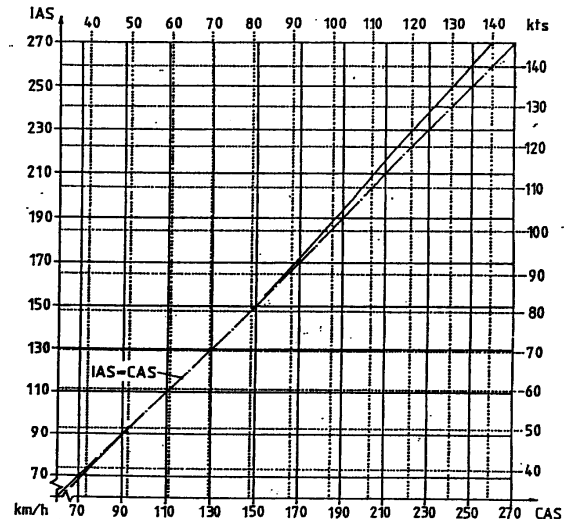

IAS = indicated airspeed  
 CAS = calibrated airspeed

**Caution:** The airspeed indicator is to be connected to the static ports and pitot probe in the fuselage nose.

## 5.2.2 Stall speeds

Minimum airspeeds in level flight

## Airbrakes retracted

Wing loading	28	33	37	40	43	46	kg/l
	5.7	6.8	7.6	8.2	8.8	9.4	lbs/ft
Stall speed	66	71	75	78	81	84	km/l
	36	38	40	42	44	45	kts

## Airbrakes extended

Wing loading	28	33	37	40	43	46	kg/l
	5.7	6.8	7.6	8.2	8.8	9.4	lbs/ft
Stall speed	70	76	80	83	86	89	km/l
	38	41	43	45	46	48	kts

Flight mass kg	Wing loading lbs	Wing loading					
		kg/m <sup>2</sup>		lbs/ft <sup>2</sup>			
Span (m)		17.2	18	20	17.2	18	20
470	1036	29.0	28.2	26.7	5.9	5.7	5.5
500	1102	30.9	30.0	28.4	6.3	6.1	5.8
550	1213	34.0	33.0	31.2	7.0	6.8	6.4
600	1323	37.0	36.0	34.1	7.6	7.4	7.0
650	1433	40.1	39.0	36.9	8.2	8.0	7.6
700	1543	43.2	42.2	39.8	8.8	8.6	8.2
750	1653	46.3	45.2	42.6	9.5	9.3	8.7

The loss of height for stall recovery is approximately 30 m (100 ft) if recovered immediately.

## 5.3 Non approved further information

## 5.3.1 Demonstrated crosswind performance

The demonstrated crosswind velocity is 15 km/h (8 kts) according to the airworthiness requirements.

## 5.3.2 Gliding performance

Performance data 18 m wingspan

Wing loading	kg/m <sup>2</sup>	(lbs/ft <sup>2</sup> )	30(6.1)	38(7.8)	45(9.2)
min.sink rate	m/s	(ft/min)	.58(114)	.65(128)	.71(140)
at V		km/h(kts)	74(40)	83(45)	90(49)
best glide ratio	/		39.4	39.7	40
at V		km/h(kts)	90(49)	101(55)	110(59)

Performance data 20 m wingspan

Wing loading	kg/m <sup>2</sup>	(lbs/ft <sup>2</sup> )	30(6.1)	35(7.2)	42.6(8)
min.sink rate	m/s	(ft/min)	.51(100)	.55(108)	.61(120)
at V		km/h(kts)	74(40)	80(43)	88(48)
best glide ratio	/		43.5	43.8	44
at V		km/h(kts)	92(50)	100(54)	110(59)

A variation in speed by + 10 km/h (5 kts) from that above will decrease the best glide angle by 0.5 glide points and increase the min. sink rate by 1 cm/sec. (2 ft/min).

The polar curves can be seen on the next page.

For optimum performance, the aircraft should be flown with a C.G. towards the rear of the allowable range. This especially improves thermalling performance. However the aircraft will be more pitch sensitive

The wing fuselage joint and the tailplane fin joint should be taped up and the aircraft thoroughly cleaned to obtain maximum performance.

The polars apply to a "clean" aircraft.

With dirty wings or flight in rain, the performance drops accordingly.

5.3.3 Flight polar

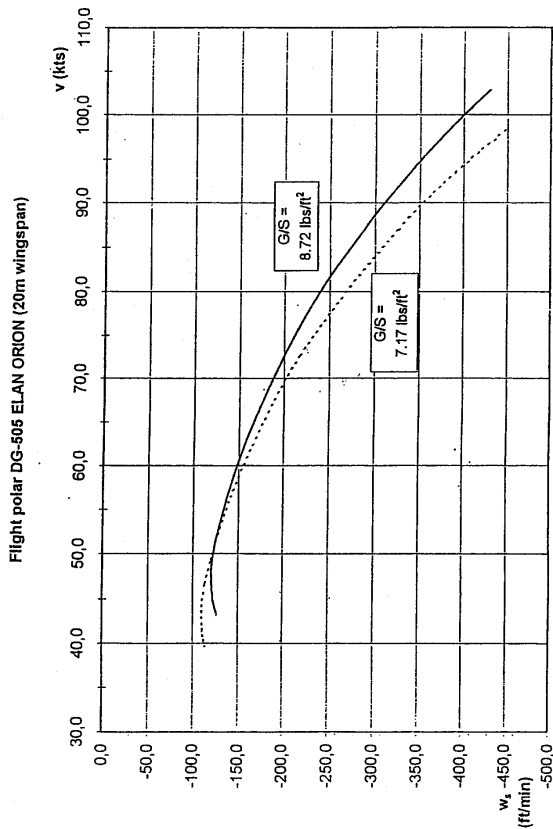

Section 6

- 6. Mass (weight) and balance
  - 6.1 Introduction
  - 6.2 Weighing procedures
  - 6.3 Weighing record
  - 6.4 Basic empty mass and C.G.
  - 6.5 Mass of all non-lifting parts
  - 6.6 Max. mass
  - 6.7 Useful loads
  - 6.8 Loading chart
  - 6.9 C.G. calculation

**6.1 Introduction**

This section contains the payload range within the sailplane may be safely operated.

A procedure for calculating the inflight C.G. is also provided.

A comprehensive list of all equipment available for this sailplane and the installed equipment during the weighing of the sailplane are contained in the maintenance manual.

**6.2 Weighing procedures**

See maintenance manual DG-500 ELAN ORION.

Datum: Wing leading edge at the rootrib.

Reference line: aft fuselage centre line horizontal. The weighing is to be executed with the battery installed in the fin (Z07 mass 4.3 kg, 9.5 lbs) and all tanks emptied.

**6.3 Weighing record**

The result of each C.G. weighing is to be entered on page 6.5. If the min. cockpit load has changed this data is to be entered in the cockpit placard as well. When altering the equipment, the new data can be gathered by a C.G. calculation. (see sect. 6.9).

The actual equipment list is enclosed in the maintenance manual.

**6.4 Basic empty mass and C.G.**

Actual data see page 6.5.

With the empty weight C.G. and the cockpit loads in the limits of the diagram on page 6.6, the inflight C.G. limits will not be exceeded.

**6.5 Mass of all non-lifting parts (WNLP)**

The max. mass of all non-lifting parts is 445 kg (981 lbs) for category 'Utility'.

WNLP is to be determined as follows:

WNLP = WNLP empty + cockpit load (pilot, parachute, baggage, barograph, cameras etc.).

WNLP empty = Total empty weight minus weight of the wings.

**6.6 Max. mass (weight)**

A) Category Aerobatic Max. weight 625 kg (1378 lbs)

B) Category Utility

Max. weight = 750 kg (1653 lbs)

Max. weight without waterballast = WNLP + W wings

**6.7 Useful load with waterballast**

Max. load with water ballast = max. weight - empty weight (only category 'Utility').

Max. load without waterballast = max. weight without waterballast - empty weight.

The data is recorded on page 6.5.

**6.8 Loading chart****6.8.1 Cockpit load see table on page 6.5.**

a) single seated

max. load in the front seat	110 kg	242 lbs
min. load in the front seat	see placard in cockpit and weighing report page 6.5	

b) two seated

max. cockpit load is 210 kg (463 lbs) with a max. of 105 kg (231 lbs) in the front seat or 110 kg (242 lbs) in the front seat and 90 kg (198 lbs) in the rear seat.

min. cockpit load in the front seat is the min. cockpit load see a) minus 40% of the load in the rear seat.

With these loads, the C.G. range given under 2.8 will be kept in the limits if the empty weight C.G. is in its limits.

With lower pilot weight necessary ballast must be added in the seat. Ballast put on the seat (lead ballast cushion) must be fastened at the connection of the safety belts.

**6.8.2 Removable Ballast (Option) see sect. 7.16.1.****6.8.3 Baggage: max. 15 kg (33 lbs)**

Heavy pieces of baggage must be secured to the baggage compartment floor (screwing to the floor or with belts). The max. mass secured on one half of the floor (left and right of fuselage centre line) should not exceed 7,5 kg (16.5 lbs).

**6.8.4 Battery in the fin:**

Only the use of the factory supplied battery Z 07, (12 V, 10 Ah, Mass 4.3 kg, 9.5 lbs) is permitted.

**Warning:** Flying is only allowed with the battery in the fin as otherwise the forward C.G. limit may be exceeded.

Instead of the battery a suitable weight of 4.3 kg (9.51 lbs) may be used.

**6.8.5 Waterballast in the wing tanks:**

The tanks have a capacity of 80 l (21.2 US gal) per wing.

**The allowed amount of waterballast**

is dependent on the empty weight and of the load in the fuselage and can be determined from the diagram on page 6.7 "ballast chart".

It is only allowed to fly with symmetric wing ballast!

## 6.8.5 Fin ballast tanks (option)

## a) Wing Ballast Compensation Tank (Tank A)

Water ballast in the fin tank should be used to compensate the forward move of C.G. due to the water ballast in the wings.

The amount of ballast in the fin is dependent on the amount of water in the wing tanks and to be determined from the following table.

in the wings		water ballast		in the fin tank	
kg	lbs	kg	lbs	kg	lbs
20	40	0.8	1.6		
40	80	1.6	3.3		
60	120	2.5	4.9		
80	160	3.3	6.5		
100	200	4.1	8.2		
120	240	4.9	9.8		
140	280	5.7	11.5		
160	320	6.6	13.1		
/	350	/	14.3		

## b) Rear Pilot Mass Compensation Tank (Tank B)

The C.G. shift due to the rear pilot can be compensated by filling the ballast tank B). This is possible even without using wing ballast. The amount of ballast is to be determined from the following table.

Mass of rear pilot		water in the fin tank	
kg	lbs.	kg	lbs
60	120	7.4	14.7
70	140	8.6	17.2
80	160	9.8	19.7
90	180	11.0	22.1
100	200	12.2	24.03
/	220	/	26.9

**Warning:**

When flying solo tank B) must be emptied! Otherwise you will fly with a dangerous C.G. position.

The compensation of 100 kg pilot weight (rear seat) raises the min. cockpit load in the front seat by 40 kg!

The resulting value (min. cockpit load in front seat from weighing without ballast + 40 kg) must be entered in the table on page 6.5 as value XX and also on the placard at the indication lights for the fin tank on the front instrument panel.

When using the fin tanks make sure not to exceed the max. weight of 750 kg (1653 lbs).

**Weighing report** (for 6.3)

Distances in mm, masses in kg

25.4 mm = 1 inch 1 kg = 2.2046 lbs.

Date of weighing:	!	!	!	!	!	!	!	!	!
executed by:	!	!	!	!	!	!	!	!	!
Date of equipment list:	!	!	!	!	!	!	!	!	!
Span	!	20 m!	17.2 m!	!	!	!	!	!	!
Empty mass	!	!	!	!	!	!	!	!	!
Empty mass	!	!	!	!	!	!	!	!	!
C.G.	!	!	!	!	!	!	!	!	!
max. mass	!	!	!	!	!	!	!	!	!
without water ballast!	U	!	!	!	!	!	!	!	!
max. load	A	/	625 kg!	!	!	!	!	!	!
without water ballast!	U	!	!	!	!	!	!	!	!
max. mass	A	/	!	!	!	!	!	!	!
with W.B. U	!	750 kg!	750 kg!	!	!	!	!	!	!
max. load	U	!	!	!	!	!	!	!	!
with W.B. U	!	!	!	!	!	!	!	!	!
min. cockpit load in front!	!	!	!	!	!	!	!	!	!
seat	!	!	!	!	!	!	!	!	!
max. load in	!	!	!	!	!	!	!	!	!
both seats U	!	210 kg!	210 kg!	!	!	!	!	!	!
A	!	/	!	!	!	!	!	!	!
with optional fin tanks XX	!	!	!	!	!	!	!	!	!
Inspector signature, stamp	!	!	!	!	!	!	!	!	!

XX = min. load in front seat for solo flying with fin tank B filled.

U = category U

A = category A

1. Weighing is to be executed with the battery (Z 07, mass 4.3 kg - 9.5 lbs) installed in the fin.
2. Weighing was executed with tailwheel with: plastic hub brass hub (see 7.16.4) (delete the inapplicable)

for 6.4 Empty weight C.G. limits

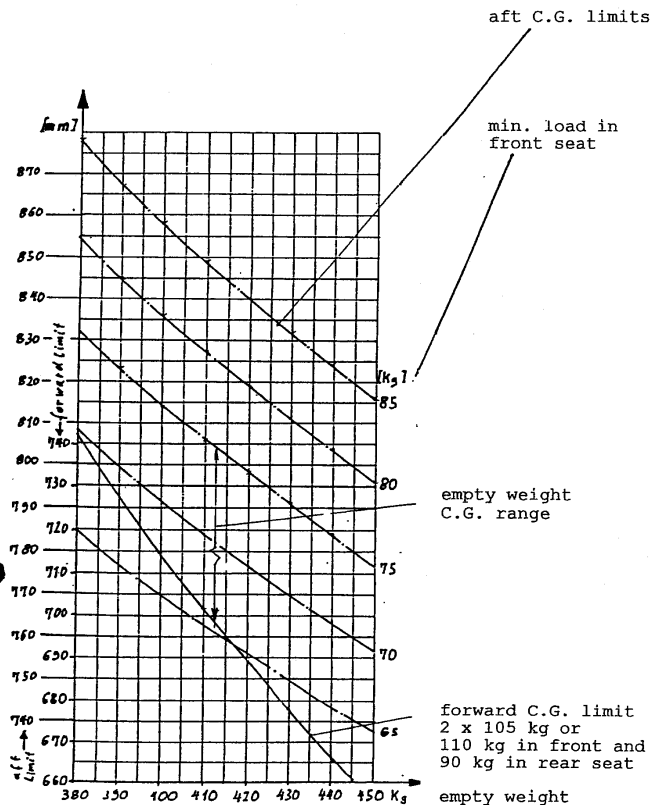

25.4 mm = 1 in., 1 kg = 2.2046 lbs.

Issued: March 2000 TN 348/14

DG-500 ELAN ORION ballast chart (for 6.8)  
to determine the max. allowable waterballast in the  
wing tanks.

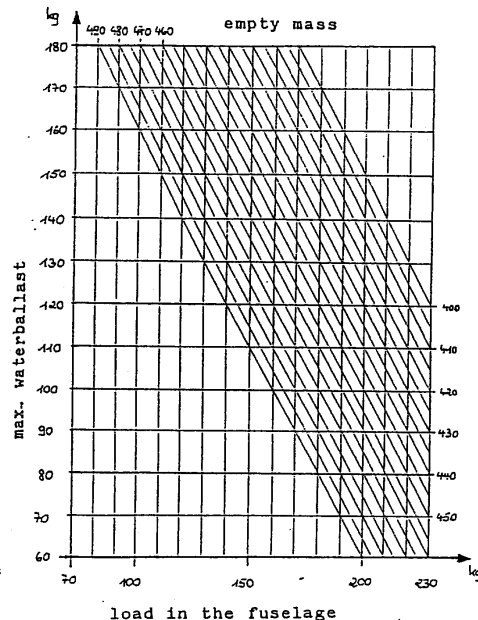

1 kg = 2.2046 lbs

3.785 kg (1) = 1 US gal.

## 6.9 C.G. calculation

The actual C.G. can be determined as follows:

For each item, the moment mass x C.G. has to be determined and to be added up and divided by the total mass. See the following example:

Item	kg	m	m kg
aircraft empty	400	0.74	296.0
Pilot front	75	- 1.35	- 101.25
rear	100	- 0.24	- 24.00
Water ballast in the wings	100	0.243	24.3
fin tank A	4.1	5.032	20.63
fin tank B	12.3	5.160	63.47
<b>Sum</b>	<b>691.4</b>	<b>XS=0.404</b>	<b>279.15</b>

CG=moment/mass

The limits of the inflight C.G. 0.185 m - 0.48 m should not be exceeded!

The most important C.G. positions (behind datum):

Pilot:

The C.G. position is dependent on the pilots shape, mass and thickness of the parachute. The pilot C.G. position can be determined by executing a weight and balance measurement with glider empty and equipped with the pilot etc. see maintenance manual. Please note, that the distance a has to be measured with both configurations, as it may change due to deflection of the landing gear. The pilot C.G. can be determined by the following equation:

$$XP = (XSF \quad MF - XSE \quad ME)/MP$$

MF = flight mass    XSF = flight C.G.    MP = pilot mass  
ME = empty mass    XSE = empty C.G.

If the actual pilot C.G. is not known, you have to take the values from the following table:

Pilot mass (kg)	pilot C.G. (m)			
	front cockpit		rear cockpit	
	f	r	f	r
110	-1,348	-1,295	-0,277	-0,232
105	-1,350	-1,296	-0,278	-0,233
100	-1,351	-1,297	-0,279	-0,234
95	-1,352	-1,298	-0,280	-0,235
90	-1,353	-1,300	-0,281	-0,236
85	-1,355	-1,301	-0,283	-0,237
80	-1,356	-1,302	-0,284	-0,238
75	-1,357	-1,303	-0,285	-0,239
70	-1,359	-1,304	-0,286	-0,240
65	-1,360	-1,305	-0,288	-0,241
60	-1,361	-1,306	-0,289	-0,242
55	-1,362	-1,307	-0,290	-0,243

Further C.G. positions:

Baggage or battery in baggage compartment:	0.31 m
Instruments in front panel:	- 1.870 m
Instruments in rear panel:	- 0.700 m
Tail wheel	5.345 m
Removable Ballast (Option see 7.16.1):	- 1.920 m
Battery in fin (see sect. 6.8)	5.306 m
Water ballast in the wings	0.243 m
Fin ballast tanks (option)	
Tank A compensation of wing ballast	5.032 m
Tank B compensation of rear pilot	5.160 m

# Flight manual DG-500 ELAN ORION

## Section 7

- 7. Sailplane and systems description
  - 7.1 Introduction
  - 7.2 Airframe
  - 7.3 Cockpit, cockpit controls and placards
  - 7.4 Flight controls
  - 7.5 Airbrake system
  - 7.6 Landing gear system
  - 7.7 Tow hooks
  - 7.8 Seats and safety harness
  - 7.9 Baggage compartment
  - 7.10 Water ballast system
  - 7.11 Section not effective
  - 7.12 Section not effective
  - 7.13 Electrical system
  - 7.14 Pitot and static system
  - 7.15 Canopies
  - 7.16 Miscellaneous equipment (Options)
    - 7.16.1 Removable ballast
    - 7.16.2 Oxygen system
    - 7.16.3 ELT
    - 7.16.4 Heavy tailwheel
    - 7.16.5 Canopy warning



## 7.1 Introduction

This section provides description and operating of the sailplane and its systems.

Refer to section 9 "Supplements" for details of optional systems and equipment.

M.M. = Maintenance manual

## 7.2 Airframe

The DG-500 ELAN ORION is a two-seater high performance sailplane.

### Construction

<b>Wings,</b>	CFRP-foam-sandwich-shell CFRP-Rovingspar caps
<b>Ailerons.</b>	CFRP/AFRP-foam-sandwich-shell
<b>Horizontal tailplane and rudder</b>	GFRP-foam-sandwich-shell
<b>Fuselage</b>	GFRP-shell, fuselage boom with Tubus core

### Canopy

Two canopies hinged at the right fuselage side.  
Canopy glass made from clear Plexiglas or Plexiglas GS green 2422 as option.

### Tailplane

T-Tail with conventional stabilizer-elevator and spring trim.

<b>Color</b>	<b>Airframe:</b>	white	
	registration numbers:	grey	RAL 7001
		or red	RAL 3020
		or blue	RAL 5012
		or green	RAL 6001

## 7.3 Cockpit, cockpit controls and placards

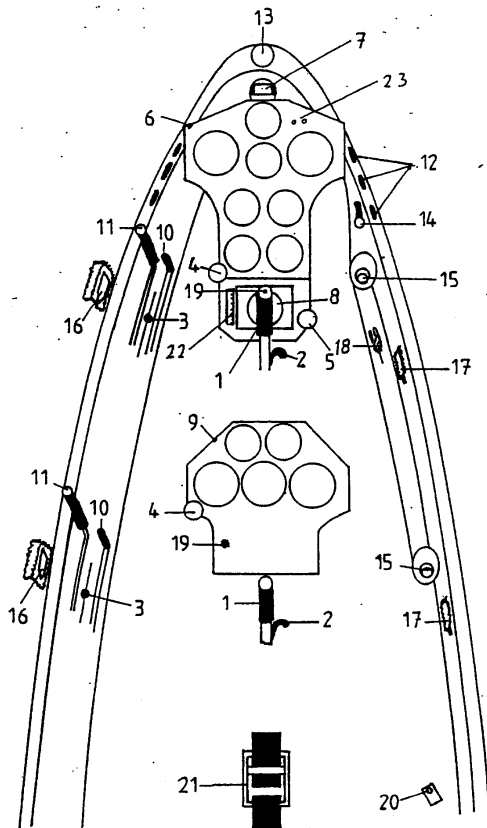

Issued: July 1995

7.3

- 1). Control Column  
The rear control stick is removable. Therefore open the snap shackle at the trim release lever and disengage the trim cable. Pull out the stick after opening the cap nut.
- 2) Release lever for the trim mechanism - green.  
Operation see sect. 7.4 elevator control.
- 3) Trim position indicator and trim preselection lever

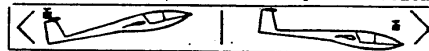

- 4) Tow release knob - yellow.
- 5) Rudder pedal adjustment knob - black (only in front cockpit)

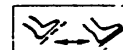

By pulling on the knob, the locking pin will be disengaged and the rudder pedals can be pulled back towards the pilot or pushed forward away from the pilot.

- 6) Front instrument Panel  
After removing the side screws at the base 2 x M 6 and after removing the screws attaching the cover to the panel 6 x M 4, the cover can be removed towards the front. The panel remains in the aircraft.
- 7) Compass installation position.
- 8) Radio installation position.
- 9) Rear Instrument Panel  
After removing the side screws attaching the panel to the cover (4 x M 4) the panel can be hinged backwards into the cockpit (take out the control stick first!).
- 10) Undercarriage retraction - extension handle (Option) - black  
forward - undercarriage down  
back - undercarriage retracted

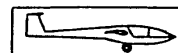
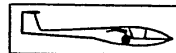

Issued: July 1995

7.4

The undercarriage is locked in the extended position by an overcentre locking arrangement and an additional safety catch. The handle is to be turned towards the cockpit wall, so that the locking catch will engage.

11) Airbrake handle - blue

The wheel brake is operated at the end of the airbrake handle travel.

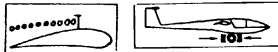

**Optional parking brake combined with an airbrake securing device (Piggott-hook):** Pull the airbrake handle back to actuate the wheelbrake and rotate the handle to the cockpit wall. A detent will engage in one of 4 notches to hold the system in this position.

In case the airbrakes mistakenly haven't been locked, a detent engages in one of several notches to avoid inadvertent deployment of the airbrakes. To open and to close the airbrakes the operating handle must be rotated into the cockpit so far that the detent passes the notches.

12) Constantly open de-misting air vents

13) Main air vent

- 14) Main air vent operating knob  
 pushed to front = closed  
 pulled = open



15) Swivel air vents

16) Canopy opening handle - white-red

- towards the nose = closed  
 into cockpit = open

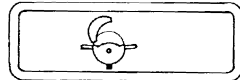

17) Canopy emergency release handle - red

- towards the nose = closed  
 into cockpit = open

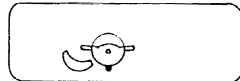

Emergency release procedure see sect. 3.2.

- 18) a) Water ballast dump handles - silver  
 upper handle = right wingtank  
 lower handle = left wingtank  
 forward = valve closed  
 into the cockpit = valve open. ly be



b) fin ballast tank dump handle for Tank A (option)

forward to dump.  
 The wing waterballast can't be dumped before dumping the fin tank (tank A)

19) Push to talk button (Option)

Senden  
 transmit

20) 12 V socket for charging the batteries.

21) Adjustment strap for the rear seat shell (to be operated on the ground)

22) Outside-air temperature gauge (required with fin tank).

23) Indication lights for the fin ballast Tank B (compensation of weight of the rear pilot) (required with fin tanks).

With Tank B empty - the light is on near the placarded value of the min. cockpit load for empty tank.

With ballast in Tank B (partly or completely filled) the other light is on near the value for the min. cockpit load with Tank B filled completely. There is no indication for intermediate values.

## 7.4 Flight controls

**Rudder control:**

See diagram 2 M.M.

Cable system with adjustable pedals in the front cockpit.

**Elevator control:**

See diagram 1 M.M.

All pushrods slide in maintenance free nylon ball guides.

Automatic control hook up system. Spring trimmer with release lever at the control stick and control knob at the left cockpit wall. To trim, you have to operate the release lever at the control stick and place the control knob to the desired position.

**Aileron control:**

See diagram 3 and 4 M.M.

Pushrods slide in maintenance free nylon ball guides.

Automatic control hook up system.

## 7.5 Airbrakes

See diagram 3 and 4 M.M.

Double storey Schempp-Hirth type airbrakes on the upper wing surface. The wheel brake is operated by the airbrake system. Pushrods in the wings slide in maintenance free nylon ball guides. Automatic control hook up system.

## 7.6 Landing gear

See diagram 7 M.M.

- a) Main wheel: retractable, assisted by a gas strut. Spring mounted with steel compression springs, locked in retracted position by an overcentre locking device. Fully sealed landing gear box, hydraulic disc brake.  
Tyre 380 x 150 6 PR  
Diameter 380 mm (15.0 in.)  
Tyre pressure 3.0 bar (44 psi)
- b) Tailwheel: Tyre 200 x 50 2 PR  
Diameter 200 mm (7.87 in.)  
Tyre pressure 4 bar (58 psi)
- c) Nosewheel: Tyre 260 x 85  
Diameter 260 mm (10.2 in.)  
Tyre pressure 2.5 bar (36 psi)

- 7.7. **Tow hooks** see diagram 5 M.M.  
**Safety release "Europa G 88"** for winch launch installed near the C.G.

"nose release E 85" installed in the fuselage nose for aerotow.

Both hooks are operated by the same handle.

7.8 **Seats and safety harness**

The front seat is constructed as an integral inner shell.

The rear seat is height adjustable. The adjustment is by means of a strap similar to the shoulder harness. As safety harness only symmetric 4-point harnesses fixed at the given fixing points are allowed.

7.9 **Baggage compartment**

Max. load 15 kg (33 lbs).

Heavy pieces of baggage must to be secured to the floor.

7.10 **Waterballast system** see diagram 6 M.M.7.10.1 **Wing tanks**

The wingtanks are constructed as double wall bags with a capacity of 80 l (21.1 U.S.gal) per wing. The dump valves are mounted in the wings and the control is hooked up automatically when rigging the glider. The upper handle is for the right and the lower handle is for the left wing tank.

7.10.2 **Fin ballast tanks (Option)**

- a) Wing ballast compensation tank (Tank A)  
max. 6.6 kg (14.31 lbs)

This is an integral tank with ventilation tube. Filling is via the dump valve. The dump valve is opened by a cable. If you overfill the tank, the excess water drains via the ventilation. The handle for the dump valve (wide plate) covers the wing tank handles, so that the wing tanks can only be emptied after opening the fin tank.

**Warning:** It is prohibited to change this system.

- b) Tank B (compensation of the mass of the rear pilot) max. 12.3 kg (27.0 lbs)  
Construction similar to tank A. Filling via a quick connector which closes by itself. Tank B can only be emptied on the ground via the filling hose, see sect. 4.2.4.

When dumping the wing tanks only tank A will be emptied, the compensation of the rear pilots mass remains even when flying without wing ballast.

## Flight manual DG-500 ELAN ORION

### 7.13 Electrical system

Battery in the fin.

For C.G. reasons the battery is installed in the fin. Only the use of the factory supplied battery Z07 (12 V, min. 10 Ah, mass 4.3 kg, 9.5 lbs.) is permitted.

The battery fuse is installed at the battery, type: G fuse 250 V with indicator 5 x 25 medium slow / 4 A.

After inserting the connector plug in the fin the battery is connected to the electrical system of the glider. If you want to charge the battery inside the glider this can be done via the socket see section 7.3 item 22).

**Warning:** Use only automatic chargers designed to charge sealed lead acid batteries. To charge the battery to its full capacity a charger with 14.4 V max. charging voltage is necessary (normal automatic chargers charge only up to 13.8V). Such a charger is available from DG Flugzeugbau code no. Z08. All current - carrying wiring conforms to aeronautical specifications.

### 7.14 Pitot and static system

see diagram 8 M.M.

Pitot probe in fuselage nose, static ports a short distance behind fuselage nose. The airspeed indicator and the altimeter are to be connected to these ports and probe. Additional holder for a TE-probe or a Multiprobe in the fin is to operate variometer and flight computer systems. To preserve the sealings inside the holder, the end of the probe should be greased with e.g. Vaseline from time to time.

### 7.15 Canopies

To **jettison** the canopies in flight see section 3.2.

#### **Removing a canopy:**

Open the canopy, detach the restraining cable and if installed detach the gas strut from the front canopy. Then close the canopy and operate the red canopy emergency release handle (right) and the white-red canopy opening handle (left). Lift the canopy upwards.

#### **Reinstalling a canopy:**

Open emergency release and canopy locking levers. Place the canopy in vertical direction onto the fuselage. Close the emergency release. Open the canopy and snap in the retaining cable and the gas-strut (if installed).

#### **Checking the canopy emergency release system:**

- a) check with open front canopy if the gas-struts (if installed) can be disengaged from their ball fittings (from canopy and from fuselage). Grease the ball fittings.
- b) check with closed canopy if the emergency release handle can be operated and if the canopy can be removed easily, resp. if the canopy will be lifted by the gas-strut. Grease the locking pins.

7.16 Miscellaneous equipment (Options)

7.16.1 Removable ballast

The ballast box (Option) at the right hand side of the instrument console underneath the carpet can accommodate 3 lead ballast weights of min 2.2 kg (4.85 lbs) each. Each weight compensates a pilot mass of 2.9 kg (6.4 lbs). With 3 weights 8.7 kg (19.2 lbs) missing pilot mass can be compensated. The lead ballast weights are to be fixed in the box with a M 8 wingnut.

7.16.2 Oxygen system

a) Oxygen bottle installation

Max. size of oxygen bottle is 7 l capacity with diameter 140 mm (5.5 in.)- If a bottle with less diameter is used, this bottle must be wrapped with plastic to come to the same diameter of 140 mm. The bottle must be fixed at its neck with a bracket Z 14 (available at DG-Flugzeugbau GmbH).

b) Installation of the oxygen equipment

To ensure a safe installation ask DG-Flugzeugbau GmbH for an installation instruction. For the installation of the Dräger Höhenatmer E 20088 you will find an installation plan 5 EP 34 in the maintenance Manual.

7.16.3 ELT Emergency Locator Transmitter

To ensure a safe installation ask DG-Flugzeugbau GmbH for an installation instruction.

For the Pointer Inc. ELT Model 3000 you will find an installation plan 5 EP 30 in the maintenance manual.

Caution: Concerning 7.16.2 and 7.16.3

The installation of such equipment has to be accomplished by the aircraft manufacturer or by an approved service station and to be inspected and entered in the aircraft log book by a licensed inspector.

### 7.16.4 Heavy tailwheel

Instead of the standard tailwheel with plastic hub a tailwheel with brass hub S 27/1 may be installed. The installation kit S 27/4 is available at DG-FLUGZEUGBAU GmbH.

The difference in mass between both hubs is 3.1 kg (6.84 lbs). With the brass hub, the min. front cockpit load is increased by 8.5 kg (18.74 lbs).

This higher value must be entered in the cockpit data placards and on page 6.5. Even if the heavy tailwheel is installed only sometimes, the higher min. cockpit load must be entered.

### 7.16.5 Canopy warning

Optionally a canopy warning device may be installed according to drawing 5EP36.

This device warns by a buzzer if the front canopy is locked and the rear canopy is still not locked or open. The buzzer is installed at the bow between front and rear canopy at the right hand side. The battery is a Lithium button cell 2430 3V/200m Ah. It is soldered and glued to the buzzer.

Section 8

8. Sailplane handling, care and maintenance

8.1 Introduction

8.2 Inspection periods and maintenance

8.3 Alterations or repairs

8.4 Parking

8.5 Trailering

8.6 Towing on the ground

8.7 Cleaning and care



## 8.1 Introduction

This section contains manufacturer's recommended procedures for proper ground handling and servicing of the sailplane. It also identifies certain inspection and maintenance requirements which must be followed if the sailplane is to retain that new-plane performance and dependability. It is wise to follow a planned schedule of lubrication and preventive maintenance based on climatic and flying conditions encountered.

## 8.2 Inspection period, maintenance

The "Instructions for continued airworthiness (maintenance manual) for the DG-500 ELAN ORION have to be followed.

- A Before each rigging all the connecting pins and bushes should be cleaned and greased. This includes the control connectors.
- B The contact surfaces of the canopies to the fuselage are to be rubbed with colourless floor-polish (canopy and fuselage side) to reduce grating noise in flight. Polish at the beginning of the flight season and then every month.
- C Once a year all the bearings and hinges should be cleaned and greased. See the greasing programme of the maintenance manual. Each year the control surface displacements, adjustments and general condition must be checked. (See the maintenance manual).

## 8.3 Alterations or repairs

It is essential that the responsible airworthiness authority be contacted prior to any alterations on the airplane, to ensure that the airworthiness of the sailplane is not impaired. It is prohibited to execute the alteration without the approval of the airworthiness authority. The manufacturer will not be liable for the alteration or for damages resulting from changes in the characteristics of the aircraft due to alteration. So it is strongly recommended to execute no alternatives which are not approved by the aircraft manufacturer.

External loads such as external camera installations are to be regarded as alterations! Repair instructions can be found in the DG-500 ELAN ORION repair manual. No repairs should be carried out without referring to the manual.

## 8.4 Tie Down, Parking

To tie down the wings use the wing cradles of your trailer. The fuselage should be tied down just ahead of the fin. On sunny days the cockpit should be closed and covered.

**Note:** Longer parking with exposure to sun and humidity will cause premature aging of the skin of your sailplane.

## 8.5 Trailing

It is recommended to carry this valuable sailplane in a factory approved enclosed trailer.

Approved fitting points:

Wing panels:

1. Wing spar as close to wing rootrib as possible or a rootrib wing cradle.
2. A wing cradle at the taper change.
3. 20 m wing tips -  
in a cradle on the fuselage in front of the fin (drawing available) or in cradles fixed to the roof of the trailer. Tips to be fixed at the spar end and in a cradle at their outboard ends.

Stabilizer:

Cradles as desired.

Fuselage:

1. A felt lined fiberglass nose cap which does not extend over the canopy, secured to floor.
2. Fuselage dolly in front of the tow hook.
3. Tail wheel well in trailer floor. Secure fuselage with a belt in front of the fin or hold it down with the trailer top (soft foam in top).

All aircraft structures should not be subject to any unusual loads. With high temperatures that can occur inside trailers, these loads in time can warp any fibre reinforced plastic sailplane.

The trailer should be well ventilated so as to prevent moisture build up which could result in bubbles forming in the gelcoat.

A solar powered ventilator is recommended.

**8.6 Towing on the ground**

- a) by towing from the nose hook using a rope with the standard double ring authorized for the release.
- b) by using a tow bar which is fixed at the tail dolly and a wing tip wheel.

The tow bar and wing tip wheel may be ordered through the Glaser-Dirks factory.

**8.7 Cleaning and Care****Exterior surfaces of the fibreglass reinforced plastic parts**

The surfaces are coated by a UP-gelcoat. This gelcoat is protected by a hard wax coating which has been applied during production with a rotating disc ("schwabbel" procedure). Do not remove the wax, because this would lead to shading, swelling and cracking of the surface. In general, the wax coat is very resistant. As soon as the wax coat is damaged or worn, a new coat has to be applied (see maintenance manual sect. 3.1). If you store your aircraft often outside, this may be necessary every half year!

**Hints for care:**

- Wash the surface only with clear water using a sponge and chamois.
- The adhesive remains of tape may be removed with petroleum ether (pure petroleum spirit) which should be applied and removed immediately, otherwise this may lead to swelling of the gelcoat.
- More stubborn dirt which cannot be removed by washing may be cleaned off with siliconefree, wax containing car polishes (e.g. 1Z Extra, Meguiars in USA)
- Longterm dirt and shading can be removed by applying a new hard wax coat (see maintenance manual sect. 3.1).

**8.7 cont.**

- Never use alcohol, acetone, thinner etc.. Do not use detergents for washing!
- Protect the surface from intense sunlight.
- Protect the aircraft from water and moisture. See sect. 8.4 and 8.5.
- Remove water that has entered and allow the aircraft to dry out.
- Never store your wet aircraft in a trailer.

**Flexiglas canopy:**

- Use clear water and a chamois for cleaning.
- Stubborn dirt and small scratches can be removed by use of the "schwabbel procedure" (see maintenance manual sect. 3.1).

**Metal parts:**

The pins and bushes for rigging the aircraft are not surface protected and must be covered with grease all the time.  
The other metal parts, especially the control stick and all handles should be preserved with metal polish occasionally.

# Flight manual DG-500

## 9. Supplements

Section		page
9.1	Introduction	9.1
9.2	List of inserted supplements	9.1
9.3	Special equipment for very small pilots	9.2

### 9.1 Introduction

This section contains the appropriate supplements necessary to safely and efficiently operate the sailplane when equipped with various optional systems and equipment not provided with the standard sailplane.

### 9.2 List of inserted supplements

Date of insertion	Document No.	Title of the inserted supplement
May 2010	Section 9.3	Special equipment for very small pilots TN500/02

### **9.3 Special equipment for very small pilots (TN500/02)**

To facilitate the operation of the glider by very small pilots 3 different items have been developed, which may be used separately or together.

#### **9.3.1 Removable seat back for the front seat**

- a) Installation of the seat back: Install the seat back with 2 screws M6x16 DIN965 4.8 BIC with cup washers 15 x M6 MS NI NR4157 to the threads which have been installed according to working instruction No. 1 for TN500/02.
- b) The seat back may be adjusted further to the front by part Z198. Fix the part to the Velcro straps installed at the rear of the seat back.
- c) Remove the head rest from the seat (screwed connection) and install a head cushion 8R80/2 to the Velcro straps installed at the front of the seat back. When removing the seat back reinstall the headrest.

#### **9.3.2 Airbrake-pushrod with additional handle in front cockpit**

For pilots with arms too short to lock the airbrakes an airbrake-pushrod with additional handle part 5St69/2 may be instead in the front cockpit according to working instruction No. 2 for TN500/02 instead of part 5St69.

This part may remain in the glider for normal operation.

#### **9.3.3 Rudder pedal plates for rear cockpit Z197**

Pilots with very short legs may clip rudder pedal plates part no. Z197 on to the rudder pedals. Plates may be installed and removed as often as desired.